



hunterstoves
GROUP



ASPECT 4
ASPECT 4 COMPACT
ASPECT 5
ASPECT 5 COMPACT
WOODBURNING STOVE
MODELS

CVSPA04W/CVSPA04CW/CVSPA05W/CVSPA05CW

Instructions for:
Installation/Operating/Maintenance/Serviceing

JINSPA04/04C/05/05C REV A 02/12/2015



CONTENTS INDEX:

WARRANTY.....	2
TECHINICAL SPECIFICATION.....	3
IMPORTANT INFORMATION.....	4
SAFETY.....	5
REMOVE INTERNAL COMPONENTS.....	6/7
ASSEMBLY INSTRUCTIONS.....	7/8
APPLIANCE DIMENSIONS.....	8
PRE INSTALLATION REQUIRMENTS.....	9
LEGAL REQUIREMENTS.....	10
CLEARANCES.....	10/11
COMMISSIONING AND HANDOVER.....	12
OPERATING INSTRUCTIONS.....	13-15
MAINTENANCE & SERVICING.....	15-17
TROUBLESHOOTING.....	18/19
SPARES.....	20-22
COMMISSIONING & INSTALLATION CHECK LIST.....	23
SERVICE RECORDS.....	24
FULL WARRANTY INFORMATION.....	25/26



HUNTER STOVES GROUP,
8 Emperor Way,
Exeter Business Park,
Exeter,
Devon. EX1 3QS

Email: info@hunterstoves.co.uk
Website: <http://www.hunterstoves.co.uk>

WARRANTY

HUNTER STOVES GROUP OFFER A STANDARD 2-YEAR WARRANTY IF PURCHASED THROUGH A RECOGNISED DEALER. 1-YEAR STATUTORY APPLIES IF PURCHASED THROUGH AN INTERNET COMPANY. WE ALSO OFFER AN EXTENDED 10-YEAR WARRANTY ON NON-CONSUMABLE PARTS. PLEASE SEE THE WARRANTY SECTION AT WWW.HUNTERSTOVES.CO.UK OR ON PAGE 25/26 OF THESE INSTRUCTIONS FOR FURTHER INFORMATION.

THE WARRANTY WILL ONLY BE VALID IF THE APPLIANCE IS INSTALLED BY AN APPROPRIATELY QUALIFIED ENGINEER IN ACCORDANCE WITH THE MANUFACTURER'S INSTRUCTIONS AND TO THE APPROPRIATE BUILDING REGULATIONS AND/OR LOCAL BY-LAWS AND SERVICED WITHIN 12 MONTHS OF INSTALLATION.

THIS APPLIANCE MUST BE REGULARLY SERVICED AND MAINTAINED, USING ONLY HUNTER STOVES GROUP APPROVED COMPONENTS FOR THE WARRANTY TO BE VALID.

Technical Specification

GENERAL	CE		Aspect 4	Aspect 4 Compact	Aspect 5	Aspect 5 Compact	
	Nominal Heat Output		Wood	4.9kW	4.9kW	4.9kW	4.9kW
	Efficiency		Wood	85.9%	85.5%	79.0%	81.6%
	Mean CO (@13% O ₂)			0.33%	0.48%	0.17%	0.18%
	Appliance Mass			56kg	52kg	72kg	79kg
	Recommended Fuels		Wood	Seasoned Wood (less than 20% moisture content)			
	Log Length			280mm	280mm	350mm	350mm
FLUES	Mean Flue Gas Temperature		230°C	212°C	277°C	267°C	
	Flue Gas Mass Flow		2.6g/s	2.7g/s	4.2g/s	3.5g/s	
	Flue Outlet Size (Top or Rear Option)		125mm	125mm	125mm	125mm	
VENTILATION	<ul style="list-style-type: none"> - Where leakage is greater than 5m³/hour/m² - Ventilation normally required = 550mm² per kW output over 5kW 				NONE		
	<ul style="list-style-type: none"> - Where leakage is less than or equal to 5m³/hour/m² - Ventilation normally required = 550mm² per kW output over 5kW 				2695mm		

For further information on ventilation please refer to Building Regulations Document J or your installer.

IMPORTANT INFORMATION

PLEASE READ THESE INSTRUCTIONS PRIOR TO INSTALLATION AND OPERATION. KEEP THESE INSTRUCTIONS IN A SAFE PLACE FOR FUTURE REFERENCE AND SERVICING.

THIS APPLIANCE WILL BECOME VERY HOT WHEN USED IN ACCORDANCE WITH THESE INSTRUCTIONS, HUNTER STOVES RECOMMEND THAT AN APPROVED GUARD IS USED TO PROTECT THE YOUNG, ELDERLY OR INFIRM FROM HARM.

THE INSTALLER COMMISSIONING SHEET CAN BE FOUND ON THE BACK COVER. PLEASE ENSURE THAT IT IS COMPLETED PRIOR TO USE.

General Guidance

It is important that your stove is correctly installed and operated as Hunter Stoves Group cannot accept responsibility for any fault arising through incorrect installation, use, maintenance or servicing.

These instructions cover the basic principles to ensure satisfactory installation of the stove, although detail may need slight modification to suit particular local site conditions.

The installation must comply with current Building Regulations, National and European Standards, Local Authority Byelaws and other specifications or regulations as they affect the installation of the appliance.

The Building Regulations requirements may also be met by adopting the relevant recommendations in the current issues of British Standards BS 8303 and BS EN 15287-1.

Only use approved fuels on this appliance. Information about this can be found on Page 15.

This is a Domestic Appliance and must only be used in accordance with these instructions. Do not place articles that are affected by high temperatures on, or near, this appliance. Do not place furniture or other items within 1 metre of the front of this appliance. See the note on material clearances on pages 10/11.

Extractor Fans and/or Cooker Hoods must not be installed in the same space or room as this can cause the appliance to emit fumes into the room.

Do not obstruct the ventilation required for the safe use of this appliance.

COMPETENT PERSONS SCHEME

Hunter Stoves Group recommend that this stove is installed by a member of an accredited competent persons scheme e.g. HETAS.

If the installer is not a member of a competent person's scheme, it is a legal requirement, in the UK, to notify your Local Building Control Officer in advance of any installation work starting.

HEALTH AND SAFETY PRECAUTIONS

Special care must be taken when installing the stove such that the requirements of the Health and Safety at Work Act are met.

HANDLING

This appliance is very heavy. Adequate facilities must be available for loading, unloading and site handling.

FIRE CEMENT

Some types of fire cement are caustic and should not be allowed to come into contact with the skin. In case of contact, wash immediately with plenty of water.

ASBESTOS

This stove contains no asbestos. If there is a possibility of disturbing any asbestos in the course of installation, then please seek specialist guidance and use appropriate protective equipment.

METAL PARTS

When installing or servicing this stove, care should be taken to avoid the possibility of personal injury.

MODIFICATION

No unauthorised modification of this appliance should be carried out.

SAFETY

WARNING – This appliance will be hot when in operation and due care should be taken. The supplied operating tool or glove may be used to open the door and operate the air controls.

AEROSOLS

Do not use an aerosol spray on or near the stove when it is alight.

FIREGUARDS

Always use a fireguard in the presence of children, the elderly or the infirm. The fireguard should be manufactured in accordance with BS8423 – Fireguards for use with solid fuel appliances.

DO NOT OVER-FIRE

It is possible to fire the stove beyond its design capacity. This could damage the stove so watch for signs of over-firing. If any part of the stove starts to glow red, the stove is in an over-fire situation and the controls should be adjusted accordingly.

Never leave the stove unattended for long periods without first adjusting the controls to a safe setting. Careful air supply control should be exercised at all times.

FUME EMISSION

Properly installed, operated, this appliance will not emit fumes. Occasional fumes from de-ashing and refuelling may occur. Persistent fume emission must not be tolerated.

This appliance should not be operated with the door open.

If fume emission persist, then the following immediate action should be taken: -

- Open doors and windows to ventilate the room.
- Let the fire go out, or eject and safely dispose of fuel from the appliance.
- Check for flue/chimney blockage and clean if required.

- Do not attempt to re-light the fire until the cause of the fume emission has been identified and corrected.

If necessary, seek expert advice.

ADVERSE WEATHER

In a small number of installations, occasional local weather conditions (e.g. wind from a particular direction) may cause downdraught in the flue and cause the stove to emit fumes. In these circumstances, the stove should not be used. A professional flue installer will be able to advise on solutions to this problem (e.g. anti-downdraught cowl).

CARBON MONOXIDE DETECTOR

Hunter Stoves recommend a Carbon Monoxide Detector that conforms to the latest issue of BS EN 50292 is placed in the same room as the appliance. The installation of such an alarm is not considered as a substitute for regular maintenance or servicing of the appliance and Flue system.

IN THE EVENT OF A CHIMNEY FIRE:

- Raise the alarm
- Call the Fire Brigade
- Close appliance air controls
- Move furniture, ornaments etc. away
- Place a fireguard in front of stove
- Check the chimney breast for signs of excessive heat.

If the wall is becoming excessively hot, move furniture away.

Ensure the Fire Brigade can gain access to your roof space in order to check for fire spread.

REMOVING INTERNAL COMPONENTS

All internal components must be removed prior to fitting the stove. This will make handling the stove easier; allow access to fixings and the flue outlet; as well as protect the internal components from damage during the installation process.



Fuel Retainer

Open the door and remove the fuel retainer. (A) Lift upwards (B) push inwards (C) remove from body.

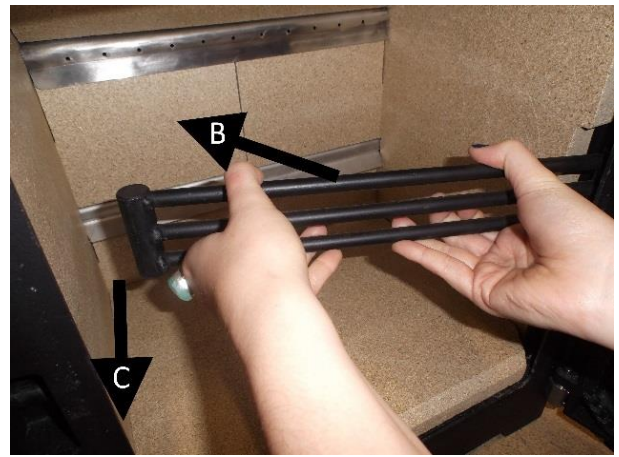
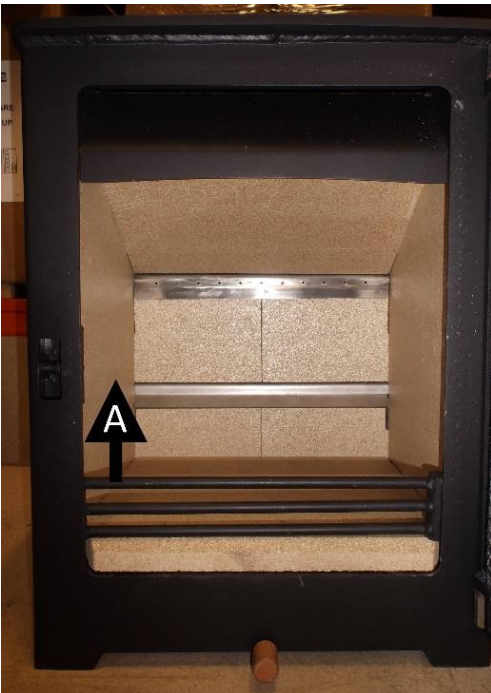

Bottom Grate Brick

Lift up bottom grate brick on one side (A) and slide out of stove body (B).



Side Bricks

Lift up baffle brick.



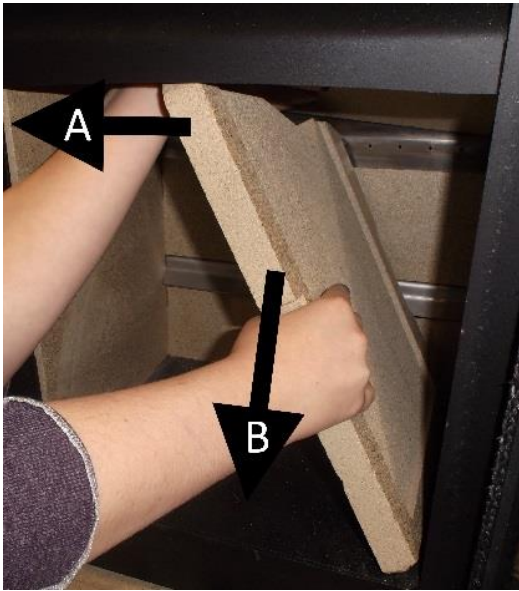

Pull top inwards (A) and then remove the brick from the stove (B).

Top Rear Bricks

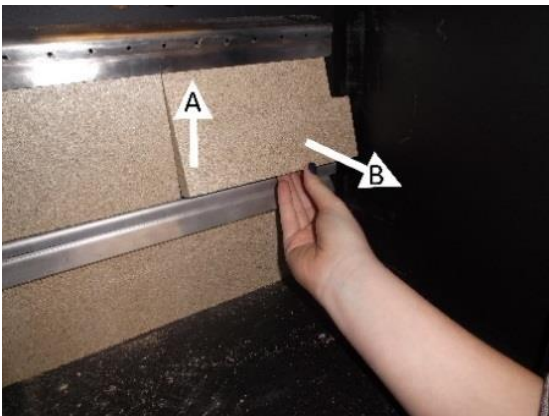

Push the brick upwards (A). Then pull the bottom edge of the rear brick forward (B) and lift the brick out of the stove.

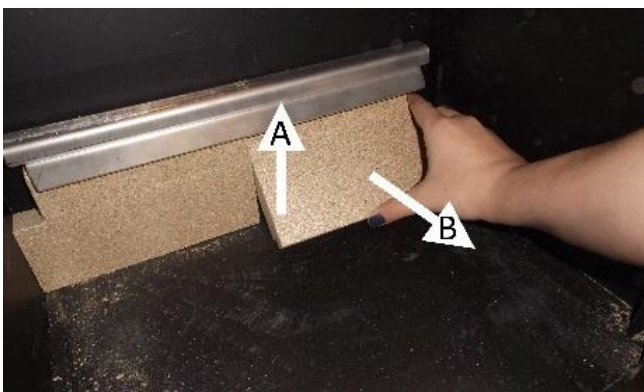

Push the brick upwards (A). Then pull the bottom edge of the rear brick forward and lift the brick out of the stove.

Baffle/Throat Plate

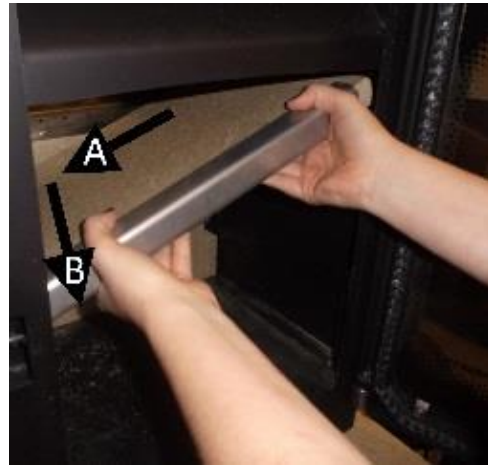

Push up and (A) drop one edge downward into the bottom of the stove and pull outwards (B).

STOVE ASSEMBLY

Flue Collar



Top or rear outlet



Place the flue collar gasket on the outlet to be used.



Wind the four M6 studs supplied into the fixing holes in the flue collar until finger tight. Place the flue collar onto the stove and tighten using the supplied washers and nuts from inside the stove.

Blanking Plate



Place the gasket on the outlet and put the blanking plate on top of this. Wind the four M6 studs supplied into the fixing holes until finger tight. Place the plate onto the stove and tighten using the supplied washers and nuts from inside the stove.

RE-ASSEMBLING THE STOVE

Refit all the internal parts by following the 'removing internal component' instructions in reverse order.

APPLIANCE DIMENSIONS

Front Dimension Aspect 4 Compact/Aspect 4

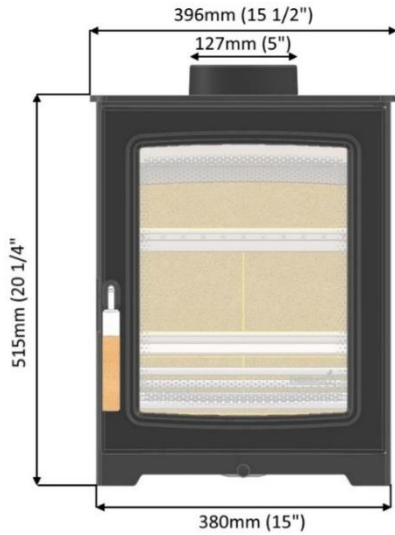

Side Dimension Aspect 4 Compact

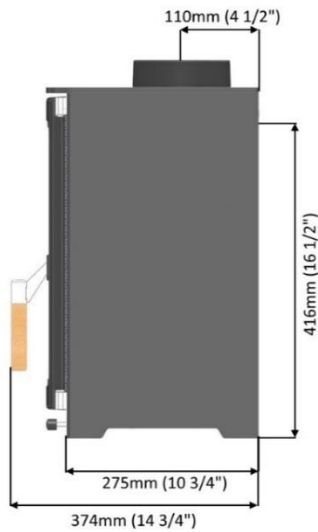

Side Dimension Aspect 4

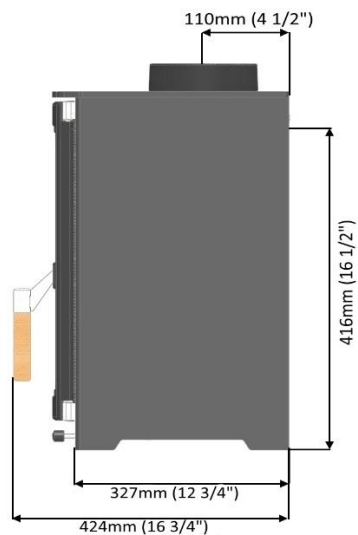

Front Dimension Aspect 5 Compact/Aspect 5

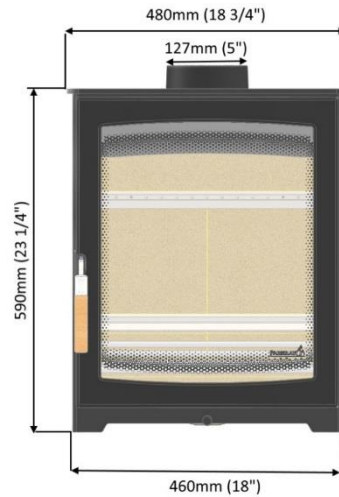

Side Dimension Aspect 5 Compact

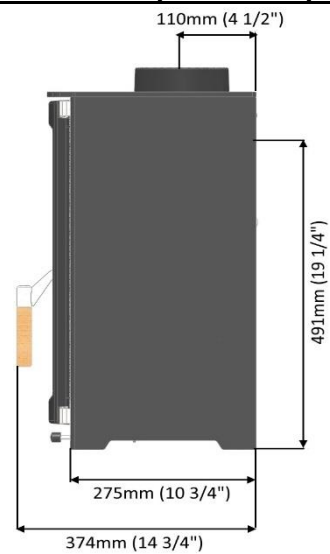

Side Dimension Aspect 5

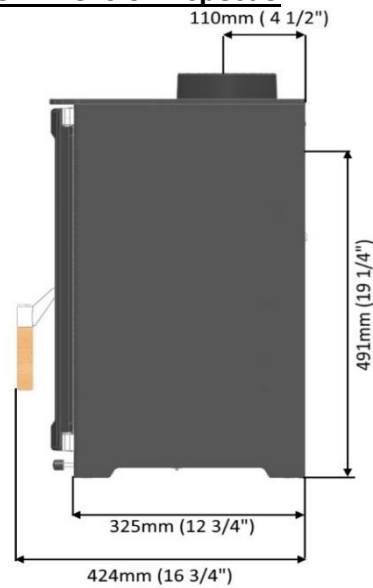

PRE-INSTALLATION REQUIREMENTS

PLEASE CHECK THE FOLLOWING:

Any existing chimney/flue system must be confirmed as suitable for this appliance as defined in Building Regulations Document J. It must be swept and inspected, by a competent person (see notes), to confirm that is structurally sound and free from cracks and obstructions.

The diameter of the Flue should not be less than Ø125mm and not more than Ø230mm. Do not connect to systems that have large voids or spaces. If any of these requirements are not met, the chimney should be lined by a suitable method.

If the chimney is suspected of previously serving an open fire it must be swept again, within a month of regular use, to clear any soot that may have been dislodged due to the variation in combustion levels and higher flue gas temperature levels. The chimney/flue system exit must comply with Building Regulations Document J. The minimum height and should terminate in accordance with Table 1.

CONNECTION TO THE CHIMNEY

An existing fireplace opening can be bricked up or sealed with a register plate. A short length of flue pipe of minimum 125mm internal diameter may then be used to connect the stove to the chimney. This flue pipe should be made of 316 grade stainless steel or vitreous enamelled steel, nominal thickness 1.2mm. Ensure that the pipe end is no closer than 76mm to the chimney walls. The length of any horizontal run of flue pipe must not exceed 125mm. It is essential that all connections between the stove and chimney-flue are sealed and made airtight.

Make provision to access the chimney/flue system for cleaning and the removal of debris. If there is no existing chimney then either a prefabricated block chimney in accordance with Building Regulations Approved Document J, or a twin-walled insulated stainless steel flue to BS4543 can be used. These chimneys must be fitted in accordance with the manufacturer's instructions and Building Regulations. New masonry and flue block chimneys must meet the requirements of Building Regulations Document J. Any connecting flue pipe systems must also meet these regulations.

Please check the suitability of the fireplace and/or surround for use with this appliance before installing it. If you have any doubts about the suitability of your chimney, consult your local Dealer/Stockist or Installation Engineer. Both the chimney and flue pipe must be accessible for cleaning and if ANY part of the chimney cannot be reached through the stove (with baffle removed), a soot door must be fitted in a suitable position.

FLUE OUTLET POSITIONS (DOCUMENT J):

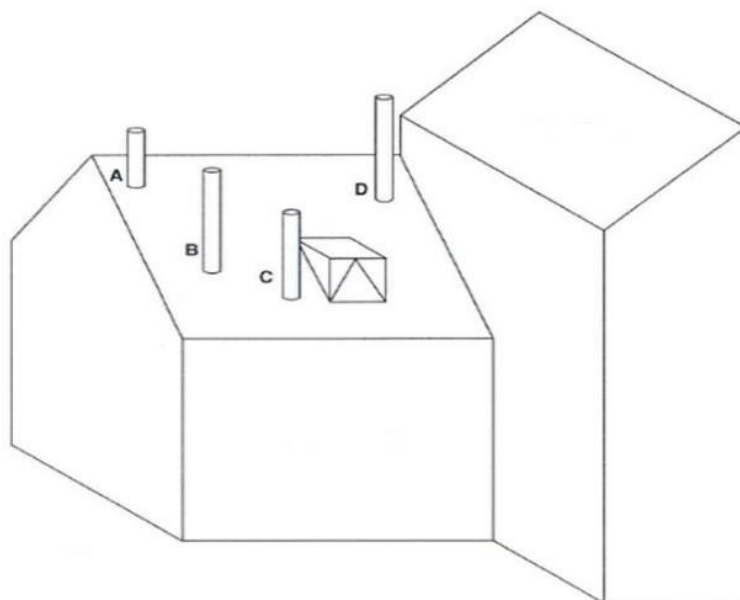

	Position on Roof	Clearances to flue exit
A	At or within 600mm of the ridge	At least 600mm above the ridge
B	Elsewhere on a roof (Pitched or Flat)	At least 2.3 M horizontally from the nearest point on the weather surface and: a) At least 1.0 M above the highest point of intersection between the chimney and weather surface; or b) at least as high as the ridge
C	Below (on a pitched roof) or within 2.3 M horizontally to an opening window or dormer	At least 1.0 M above the top of the opening
D	Within 2.3 M of an adjoining or adjacent building, whether or not beyond the boundary	At least 600mm above any part of the adjacent building within 2.3 M

A full copy of Document J can be found here:
http://www.planningportal.gov.uk/uploads/br/BR_PDF_ADJ_2010.pdf

LEGAL REQUIREMENTS

Hunter Stoves Group requests that before installation and/or use of this appliance that you read these instructions carefully to ensure that all the relevant requirements are fully understood.

These instructions cover the basic principles to ensure satisfactory installation of the stove, although detail may need slight modification to suit particular local site conditions. In all cases the installation must comply with current Building Regulations, Local Authority Byelaws, European and National Standards and other specifications or regulations as they affect the installation of the stove.

It should be noted that the Building Regulations requirements may be met by adopting the relevant recommendations given in British Standards BS 8303, BS 6461 and BS 7566 as an alternative means to achieve an equivalent level of performance to that obtained following the guidance given in Approved Document J.

Your local Building Control Officer can advise you regarding the interpretation of the Regulations should there be any questions.

This appliance must be installed by a Registered Installer (see Competent Persons Scheme) or approved by your local Building Control Officer.

All works undertaken must be carried out with due care and attention to meet the requirements of the Health & Safety code of practice and any other legislation that may have been introduced since the publication of these instructions.

Competent Persons Scheme

Members of the following schemes may self-certify the installation of this stove. If the installer is not a member of one of these schemes, your local Building Control Department must approve the installation.

Scheme	Web address	Telephone
APHC (Association of Plumbing and Heating Contractors (Certification) Limited)	www.aphc.co.uk	02476 470 626
Building Engineering Services Competence Accreditation (BESCA Limited)	www.hvca.org.uk / www.besca.org.uk	0800 652 5533
HETAS Ltd (Heating Equipment Testing and Approval Scheme)	www.hetas.co.uk	01462 634721
NAPIT Registration Ltd	www.napit.org.uk	0870 444 1392
NICEIC Group Ltd	www.niceic.org.uk	0800 013 0900

AIR SUPPLY

The room or space containing this appliance does not need a permanent, unobstructed air opening unless the air permeability rating is less than or equal to 5m³/hour/m² .

If a draught stabiliser is fitted, the air opening should be at least 1470mm².

Due consideration should be given to air requirements for any other appliance in the same room or space.

Any air opening must be kept clear from blockage or obstruction.

HEARTH/ MATERIAL CLEARANCES

Hearth constructions must comply with the current building regulations.

Your stove must be installed on a floor with adequate load-bearing capacity, otherwise suitable measures should be taken.

If the existing construction does not meet this prerequisite, suitable measures (e.g. load distributing plate).

Care should be taken to level the stove using the adjusting screws in the feet.

MATERIAL CLEARANCES

COMBUSTIBLE MATERIAL

Minimum Distances to Combustible Material				
	ASPECT 4	ASPECT 4 COMPACT	ASPECT 5	ASPECT 5 COMPACT
Behind the stove	200mm	100mm	200mm	200mm
At the side of the stove	600mm	500mm	600mm	550mm
In front of the stove	900mm	900mm	900mm	900mm

****Note:** To achieve the specified distances to combustible materials, twin-wall insulated flue pipe must be used, starting no higher than 95mm above the stove. The optional rear and upper heat shields must be fitted to achieve these distances. The standard clearance without these would revert to 900mm. Combustible material refers to any material that will degrade when subjected to heat e.g. plaster.

TOP HEAT SHIELD

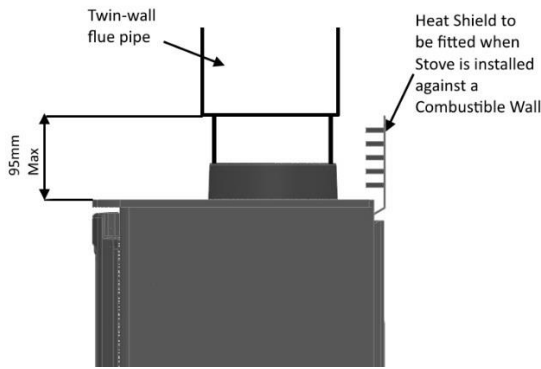

REAR AND TOP HEAT SHIELD

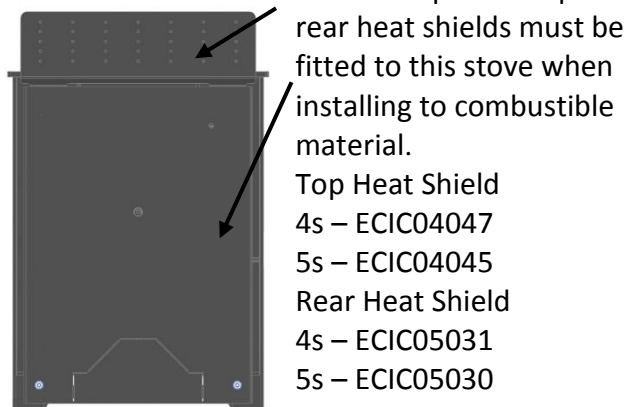

NON COMBUSTIBLE - FIREPLACE RECESS

Plan view:

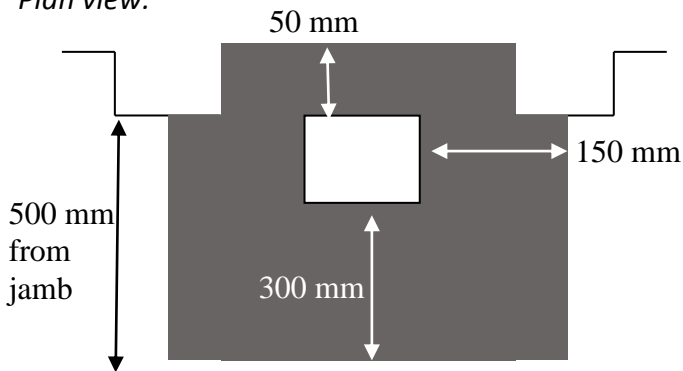

Side view:

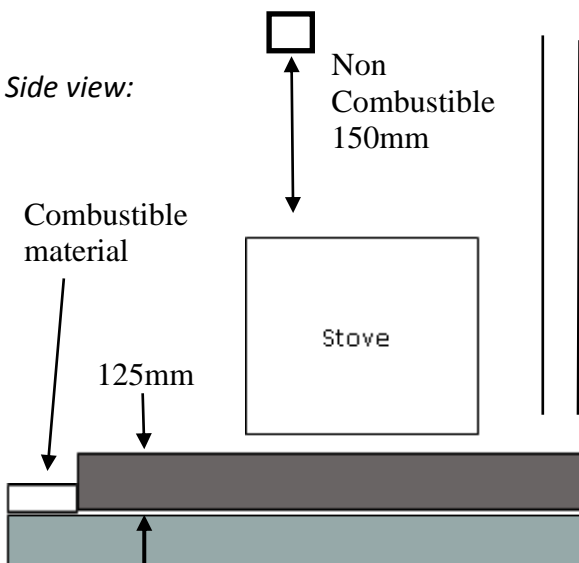

The stove can be recessed in a suitable sized fireplace but a permanent free air gap of at least 150mm on top and 50mm (although we recommend 150mm) around the sides and 50mm at the back of the stove to obtain maximum heat output and for access to the rear of the stove.

The hearth should extend at least 300 mm from the front of the stove. The stove should stand wholly above a solid, non-combustible hearth, at least 125 mm thick (this may include the thickness of a solid floor or a non-combustible decorative hearth).

NON COMBUSTIBLE – FREE STANDING

Plan view:

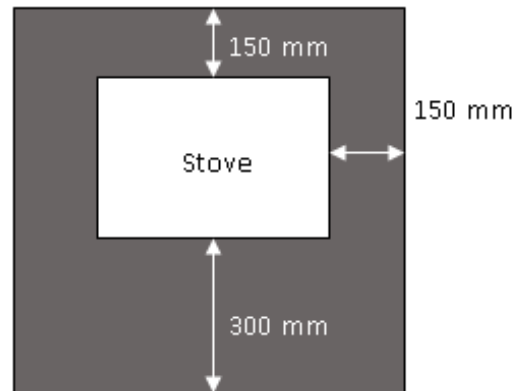

Side view:

Change in level to mark safe perimeter

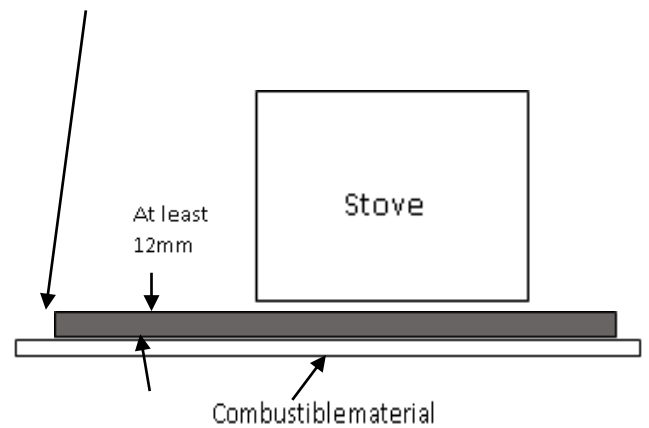

If the stove is not to stand in a recess, it may stand wholly above a hearth made of non-combustible board / sheet material or tiles, at least 12mm thick. The hearth should extend at least 150 mm from the sides and rear of the stove, and at least 300 mm from the front of the stove (350mm recommended).

All walls shown in the above diagrams are non-combustible unless otherwise indicated. All non-combustible walls closer than 300mm to the stove should be at least 75mm thick.

COMMISSIONING & HANDOVER

APPLIANCE CHECK

Please check that all components are correctly assembled and working correctly.

Ensure the Air Controls are working correctly. Hunter Stoves Group recommend that you carry out a smoke draw test to check the soundness of the chimney/flue system and seals:

Place a Smoke Pellet in the centre of the Grate, ensure that all of the Air Controls are fully open and close the Door.

The smoke should now be drawn up the chimney and you should be able to see it exit from the chimney/flue terminal.

We recommend that you do this test with all of the windows and doors, to the room where the appliance is fitted, closed.

If there any adjoining room(s) that have an Extractor Fan fitted, open the adjoining door to ensure that the chimney/flue system is not compromised when the fan is operating. If there is a ceiling fan fitted in the room, please operate it and ensure that it does not affect the operation of the chimney/flue system.

If any of these tests fail, please re-check the suitability of the chimney/flue system together with the ventilation.

A small fire can now be lit and allow the appliance to heat up slowly ensuring that no products of combustion enter into the room.

Carry out a spillage test using a smoke match around the door opening.

If there is excessive spillage, please allow the appliance to cool and then re-check the chimney/flue system and ventilation.

Do not run the stove at full output for at least 24 hours.

On completion of the commissioning:

Upon completion, allow a suitable period of time for any fire cement and mortar to dry out. Do not run the stove at full output for at least 24 hours.

Please instruct the user on the safe operation of this appliance, how the controls work and basic maintenance requirements.

Ensure that the operating instructions and appliance tools are left with the customer and the check lists have been filled out correctly.

Please advise the customer on the correct use of the appliance with the fuels likely to be used on the stove and warn them to use only the recommended fuels for the stove.

Advise the user on what to do should smoke or fumes be emitted from the stove.

The user should be warned to use a fireguard to BS 6539 in the presence of children, aged and/or infirm persons.

Hunter Stoves Group also recommend that a CO alarm is fitted into the room where the appliance is located.

FLUE DRAUGHT

If the draught exceeds the recommended maximum, a draught stabiliser must be fitted so that the rate of burning can be controlled and to prevent over firing. If the reading is less than the recommended minimum, then the performance of the appliance will be compromised. The flue draught should be checked under fire at high output with windows and doors closed. To take the reading remove one of the coach bolts in the flue collar and put the probe in the hole.

Minimum Draught – 1.2mm Water Gauge
Maximum Draught – 2.5mm Water Gauge

THE CLEAN AIR ACT 1993 AND SMOKE CONTROL AREAS

Under the Clean Air Act 1993 local authorities may declare the whole or part of the district of the authority to be a smoke control area. It is an offence to emit smoke from a chimney of a building, from a furnace or from any fixed boiler if located in a designated smoke control area. It is also an offence to acquire an "unauthorised fuel" for use within a smoke control area unless it is used in an "exempt" appliance ("exempted" from the controls which generally apply in the smoke control area).

The Secretary of State for Environment, Food and Rural Affairs has powers under the Act to authorise smokeless fuels or exempt appliances for use in smoke control areas in England. In Scotland and Wales this power rests with Ministers in the devolved administrations for those countries. Separate legislation, the Clean Air (Northern Ireland) Order 1981, applies in Northern Ireland. Therefore, it is a requirement that fuels burnt or obtained for use in smoke control areas have been "authorised" in Regulations and that appliances used to burn solid fuel in those areas (other than "authorised" fuels) have been exempted by an Order made and signed by the Secretary of State or Minister in the devolved administrations.

Further information on the requirements of the Clean Air Act can be found here:

<http://smokecontrol.defra.gov.uk/>

Your local authority is responsible for implementing the Clean Air Act 1993 including designation and supervision of smoke control areas and you can contact them for details of Clean Air Act requirements.

Operating Instructions

Read the 'General Guidance' Section at the start of these instructions before operating your stove for the first time.

Allow sufficient clearance between the stove and pictures, plasma screen televisions or ornaments etc., as these could be damaged and could potentially create a fire hazard (For more information read the 'Material Clearance' section of these installation instructions).

WARNING – This appliance will be hot when in operation and due care should be taken. The supplied operating tool or gloves may be used to open the door and operate the air controls.

PLEASE NOTE

Your Building Insurance Company may require you to inform them of this new installation and that the work has been carried out correctly. Please check your policy to ensure that it is still valid when this installation is complete.

USING THE APPLIANCE FOR THE FIRST TIME

We recommend that the appliance is left for 24 hours after installation to allow the fire cement, fixing glues, etc. to cure.

With the painted finish we recommend that you have two or three small fires before you operate your stove to its maximum heat output. This is to allow the paint to cure in steadily and to give a long service life of the paint finish.

During this curing in process you may notice an unpleasant smell. It is non-toxic, but for your comfort we would suggest that during this period you leave all doors and windows open.

AEROSOLS

Do not use an aerosol spray on or near the stove when it is alight.

AIR CONTROL

This stove has been designed to burn far more efficiently than a traditional stove if used correctly, with the obvious notable feature of CLEAN GLASS.

It is essential that the stove has an adequate air supply for combustion and ventilation.

AIR CONTROL

The air intake into the stove is controlled by one push pull air control rod. Both Primary and Secondary are operated using this control rod.

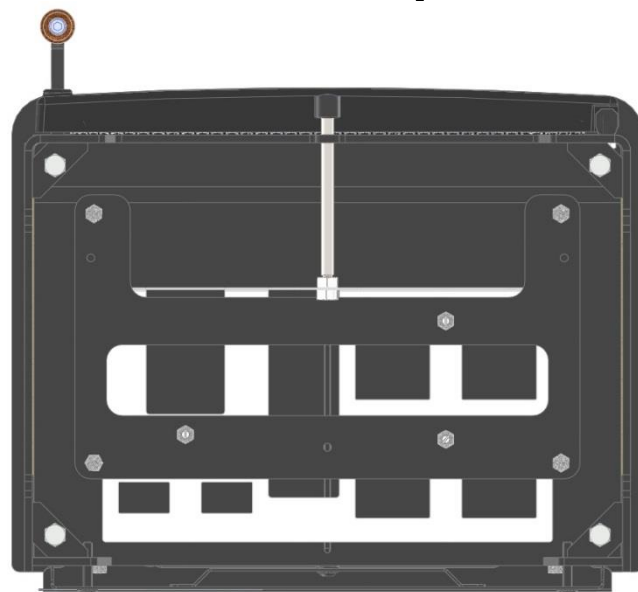

- A) When the air control rod is pushed in fully then both the Primary and Secondary air intakes are in the closed position.

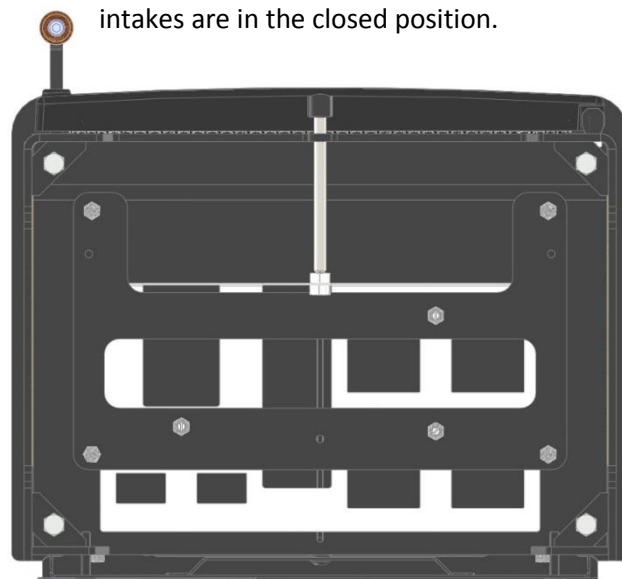

- B) To operate pull the air control rod away from the stove. For the Primary and Secondary air to be in the fully open position pull the air control rod knob away from the stove until it stops. This is necessary for lighting the stove.

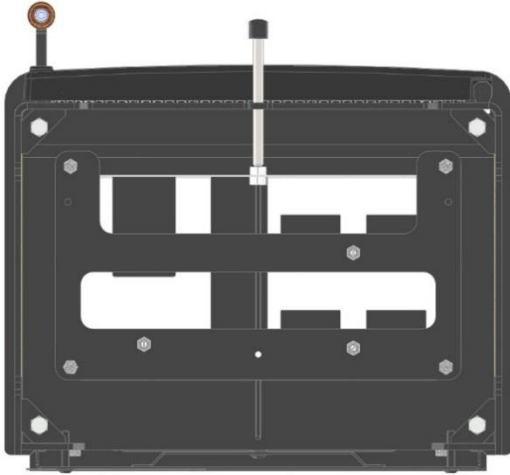

- C) The air intake needs to be between 25% - 50% open to obtain the best result for burning wood.

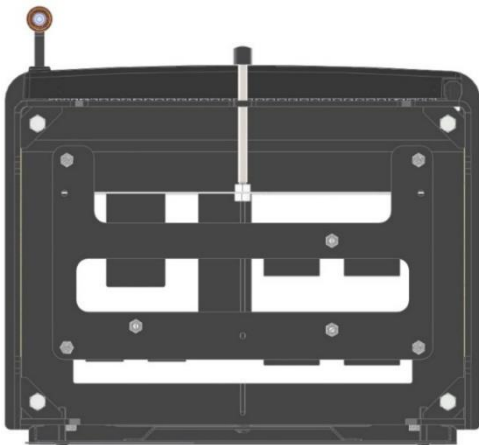

Warning! – This appliance will be hot when in operation and due care should be taken.

We advise that suitable gloves, or the operating tool is used when operating the air control, and when opening the door.

Primary Air

The primary air provides a conventional air draught to the bed of the fire.

Secondary Air

The secondary air is the air control for the airwash that keeps a clean and uninterrupted view of the fire.

Tertiary Air

The tertiary air aids in good secondary combustion of the fuel and reducing emissions into the chimney and environment.

BURNING WOOD

Lighting the Stove

First, load the fire with starting fuel, i.e. paper, dry sticks and/or firelighters. Light the fire at the base with the air control fully open (B). Allow the fuel to reach a steady glow and build the fire up gradually. Once you have a good fire established across the grate bed, further fuel can be added as required.

Reduced Combustion

In order to shut down the stove then push the air control rod fully in (A). If the controls are left in this position, the fire will be starved of air and will die down. If you want to revive the fire then pull the air control rod until it is fully open (B) then push it in halfway for normal burning (C).

Warning! - The stove will remain hot for a considerable time after the fire has been extinguished.

Notes on Woodburning

With a full load of wood, the stove will need to be refuelled approximately once every hour. Wood can be stacked in the stove, but no higher than the tertiary air holes at the back of the firebox.

Overloading the stove can cause excess smoke to be emitted. Wood burns most efficiently with the air control halfway open (C).

Wood burns most efficiently on a bed of ash and it is therefore only necessary to remove surplus ash from the stove occasionally. Ash can be removed with the tool supplied.

If there is insufficient burning material in the fire bed to light a new fuel charge, excessive smoke emission can occur.

Refuelling must be carried out with a sufficient quantity of glowing embers and ash, so that the new fuel charge will ignite quickly. If there are too few Embers, add some kindling to prevent excessive smoke. After refuelling leave the air control fully open for one minute before reducing to the desired setting.

(When refuelling it is important to have a damper in the open position if you have one.) If a damper is needed a full size flue collar (CH05010) will need to be fitted.

Maximum Length:
See page 2.

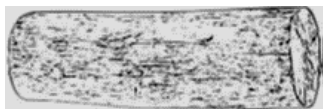

Ensure your logs are well seasoned with a moisture content of less than 20%

RECOMMENDED FUELS

Hunter Stoves Group recommend that only wood logs with a moisture content of less than 20% should be burnt on this appliance.

Burning wet or unseasoned wood will create excess smoke emissions, tar deposits in the stove and chimney and will not produce a satisfactory heat output.

WARNING - DO NOT BURN BITUMINOUS COAL, PETRO-COKE, OTHER PETROLEUM BASED FUELS OR TREATED WOOD SUCH AS PALLETS AS THIS WILL INVALIDATE THE PRODUCT WARRANTY. HOUSEHOLD WASTE MUST NOT BE BURNT ON THIS APPLIANCE.

A list of approved fuels can be found at:-

HETAS Ltd – Telephone 01242 673257 –
http://hetas.co.uk/public/hetas_guide.html

Solid Fuel Association – Telephone 0800 600 000 –
www.solidfuel.co.uk

MAINTENANCE AND SERVICING

WARNING!

NO unauthorised modification of this appliance should be carried out.

IMPORTANT!

In order to ensure continued compliance with current Building Regulations and Local Authority Byelaws, this appliance requires regular maintenance by a competent person. N.B. Refer to the 'Removing Internal Components' section of the installation instructions for details on how to remove each component.

PERIODS OF PROLONGED NON-USE

If the stove is to be left unused for a prolonged period, then it should be given a thorough clean to remove ash and unburned fuel residues. To enable a good flow of air through the appliance to reduce condensation and subsequent damage, leave the air controls fully open. If the appliance has been unused for a long period, such as during the spring and summer months, a competent person should check

the chimney for potential obstructions before lighting the stove *i.e. get the chimney swept before the start of the heating season?*

BAFFLE

This should be removed and cleaned at least once a month to prevent any build-up of soot or fly ash that could lead to blocked flue ways and dangerous fume emission. If the baffle is removed the chimney/flue way can be swept through the appliance.

STOVE BODY

Painted Finish - The stove is finished with a heat resistant paint and this can be cleaned with a dry microfiber cloth. Do not clean whilst the stove is hot. **At no point should any water based or other cleaning products be used on the stove.** The finish can be renovated with Hunter Stoves paint.

GLASS PANEL

Printed glass should not be cleaned using cleaners high in alkaline or acidic content. Clean the glass panel when cool with a propriety glass cleaner by applying the cleaner to a cloth. Do not apply directly to the glass as this could cause run of which could soak into the rope seals around the edge of the glass.

Highly abrasive substances should be avoided as these can scratch the glass and make subsequent cleaning more difficult. Wet logs on heated glass, a badly aimed poker or heavy slamming of the doors could crack the glass panels. The glass will not fracture from heat.

Should you need to replace a glass panel please ensure you purchase a new Gasket at the same time. Please check periodically that the glass clips and screws have not become loose. They should only be finger tight to allow for the expansion and contraction of the glass.

GASKETS

All gasket used on this appliance are produced from a heat resistant material called Manniglas.

The glass gasket will have to be replaced when a new piece of glass is fitted as the gaskets become brittle after firing the stove.

Over time you may also find that the gasket changes colour. This is due to a reduction in the pigment used in the manufacture of the product and no cause for concern.

FIREBRICKS

In normal use, these can last for many years. It is possible however, to crack them if logs are continually jammed against them or if they are frequently struck with a poker. Check periodically for seriously cracked bricks, which can be replaced with new, available from your dealer or our spares website www.hunterstoves.co.uk.

DOOR CATCH ASSEMBLY

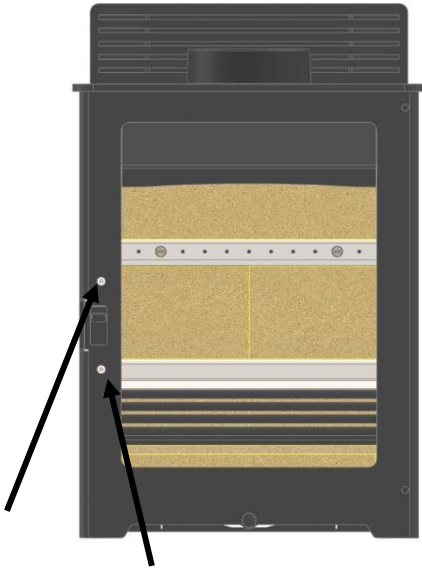

The door catch assembly (Diagram A) is adjustable up and down by loosening the two screws as shown by the arrows above. A shim (Diagram B) is also available that can be fitted/removed without taking the door catch assembly out of the stove. This allows the door catch to be moved inwards or outwards.

DIAGRAM A

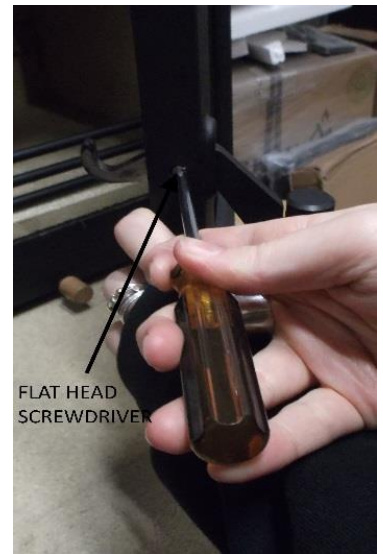

DIAGRAM B



CHANGING THE DOOR HANDLE

Remove screw holding in door hook. Pull hook out of hole in door.



To change the door handle. Use a 5mm Allen Key to undo the screw. Once screw is removed handle will come off. To attach work in reverse.



ROPE

Check the 12mm rope around the door. If rope is becoming detached, use rope glue to reattach it. If the rope is in a poor condition, a replacement rope kit may be ordered from the Hunter Stoves Group spares range.

CHIMNEY AND FLUE WAYS

It is important that the chimney, flue ways and any connecting flue pipe are swept regularly. This means at least once a year for smokeless fuels and at least twice a year for wood and other fuels. The baffle will need to be removed from its supports in order to sweep the chimney (see assembly instructions). Only wire-centred sweeps' brushes fitted with a guide wheel should be used. If it is not possible to sweep all parts of the chimney through the appliance, ensure there is adequate access to cleaning doors. If the stove is fitted in place of an open fire, then the chimney should be swept one month after installation to clear any soot falls which may have occurred due to the difference in combustion between the stove and the open fire.

ANNUAL SERVICE

Hunter Stoves Group recommend that this appliance is serviced annually, preferably prior to the start of the heating season, thus avoiding any delay in receiving replacement components, should you need them.

If you feel unable to undertake this task, Hunter Stoves recommend that you contact the installation engineer for advice.

Remove all the internal components:

Base brick, Side bricks and brick Baffle. Clean them with a soft brush and inspect them for damage.

Sweep the chimney/flue system if necessary.

Clean down the internal surfaces of the appliance using a scraper or wire brush.

Inspect these surfaces for damage/corrosion. If corrosion or damage is found, we advise that you consult with your installer about rectification/repair. Brush out or vacuum the inside of the appliance and re-fit the internal components.

Inspect the Glass and Gasket. Clean the Glass with a non-abrasive cleaner if required. If the Gasket is torn or damaged, we recommend that it is replaced to ensure that no products of combustion enter the room when the appliance is used.

Painted Finish – Use a dry microfiber cloth to clean the outer surface and touch up the paint if necessary. Burn the appliance at a low rate, after maintenance, to allow any new seals, paint or glue to cure properly. The appliance may emit unpleasant odours during this process, please ensure the room is well ventilated. The paint can be ordered through our website www.hunterstoves.co.uk.

Further Information

For extra guidance on using your stove, please visit our YouTube channel by searching 'Hunter Stoves Group' or see the helpful hints section of our website; www.hunterstoves.co.uk.

This appliance is suitable for intermittent burning.

All genuine Hunter Group spares can be purchased through our website www.hunterstoves.co.uk/spares or through your authorised dealer.

TROUBLESHOOTING

	ISSUE	CAUSE	RESOLUTION
OPERATION	Problem starting the fire and keeping it burning	Low flue draught	Speak to your installer
		Wood with moisture content over 20%	Ensure use of dry seasoned wood with less than 20% moisture content
	Unable to control fire	High flue draught	Speak to your installer
	Short burn time	Wood with moisture content over 20%. Insufficient amount of fuel – refer to page 15 (Notes on Woodburning)	Ensure use of dry seasoned wood with less than 20% moisture content
	Over firing	High flue draught	Speak to your installer
		Air controls left fully open	Close air control to reduce output
	Low heat output	Low flue draught	Speak to your installer with advice on a suitable flue system.
		Wet wood (over 20% moisture content)	Ensure use of dry seasoned wood with less than 20% moisture content
Excessive fuel consumption	High flue draught	Speak to your installer	
	Over dry wood	Do not use constructional timber of pallet wood	
SMOKE PROBLEMS	Smoke and small flames	Wood with moisture content over 20%	Ensure use of dry seasoned wood with less than 20% moisture content
	Excessive smoke spillage into room when appliance door is opened	Low flue draught	Speak to your installer
		Incorrect additional ventilation air in to the building	Speak to your installer
	Continuous smoke spillage into the room when stove is in use	Blocked flue	Open all doors and windows to ventilate the room. Allow the fire to go out. Check flue for blockage. Do not re-use until the problem has been identified. If in doubt speak to your installer.
Blue/grey smoke from chimney	Wood with moisture content over 20%	Ensure use of dry seasoned wood with less than 20% moisture content	
ADVERSE WEATHER	Windy days causing spillage into the room	Down draught in flue caused by air turbulence due to nearby buildings or trees.	Weather conditions combined with the flue terminal position can have an effect on the stoves performance. Speak to your installer.
	Calm days causing spillage into the room	Over size flue giving poor flue draught	Weather conditions combined with the flue terminal position can have an effect on the stoves performance. Speak to your installer.
	Damp/Rainy days lighting and burning problems	Flue temperature low or rain water inside flue.	Use good quality wood to start and maintain the fire, speak to your installer to fit a rain cowl.
	Wind noise	High flue draught	Speak to your installer.

	ISSUE	CAUSE	RESOLUTION
THE APPLIANCE	Creosote build-up in chimney	Wood with moisture content over 20%	Use dry seasoned wood (less than 20% moisture content). Operate at a high temperature for short periods each time the appliance is used to avoid large build-ups of tars and creosotes.
	Tar coming from flue joints	Appliance operated at continuous low temperatures	Operate at a high temperature for short periods each time the appliance is used to avoid large build-ups of tars and creosotes. See user instructions for correct use of air control
		Using poor quality wood	Use dry seasoned wood (less than 20% moisture content).
	Dirty firebricks/glass	Wood with moisture content over 20%	Use dry seasoned wood (less than 20% moisture content).
	Glass blackening	Using poor quality wood	Use dry seasoned wood (less than 20% moisture content).
		Low flue draught	Speak to your installer.
		Incorrect use of air control	See user instructions for correct use of air control
Appliance operated at low temperatures continuously		Operate at high output for short periods. See instructions for correct use of air control.	

FLUES	<p>Flue systems have two main functions:</p> <ol style="list-style-type: none"> 1) To remove the smoke, fumes and combustion gasses from the building safely and efficiently 2) To provide a sufficient amount of flue draught (suction) in the appliance to ensure the fire keeps burning correctly. <p>The flue draught is caused by rising hot gases when the appliance is burning.</p> <p>If any flue issues persist then speak to your installer before continuing to use the stove.</p>
--------------	--

STOVE CARE PRODUCTS

All replacement parts and stove care products are available from our website shop www.hunterstoves.co.uk.

Glass Cleaner (150mm Aerosol) – SCPGC



Fire Cement (500gm) – SCPFC500



Rope Glue (25ml) – SCPGLUE25ML



Gauntlet Gloves (pair) – SCPGNTGLV



Touch up pain with brush (236ml) – SCPPB



Spray Paint (400ml) – 40.011400



Black Chrome Handle – ECIC04063BC



Stainless Steel – ECIC04063SS



Wood Handle Walnut – ECIC04063W



Wood Handle Oak – ECIC04063O



Flue Damper (taller flue collar needed CH05010) – HHR99992



Flue Gather Kit – HHR99987K



Multifuel Conversion Kit –

- JPA04 - PARKRAY ASPECT 4
- JPA04C - PARKRAY ASPECT 4 COMPACT
- JPA05 - PARKRAY ASPECT 5
- JPA05C - PARKRAY ASPECT 5 COMPACT

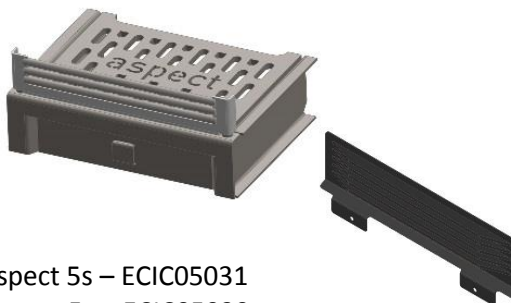

Heat Shields – Top - Aspect 4s – ECIC04047 // Aspect 5s – ECIC05031
 - Rear – Aspect 4s – ECIC04045// Aspect 5s – ECIC05030

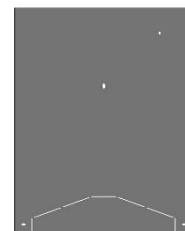

Spares Information

DOOR FRONT VIEW ASPECT 4 COMPACT/ ASPECT 4

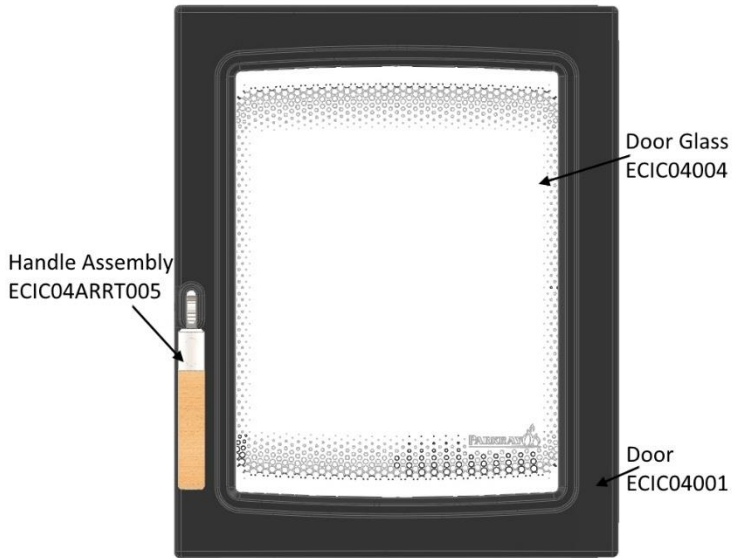

**Complete Door
ECIC04ARRT002**

DOOR REAR VIEW ASPECT 4 COMPACT/ ASPECT 4

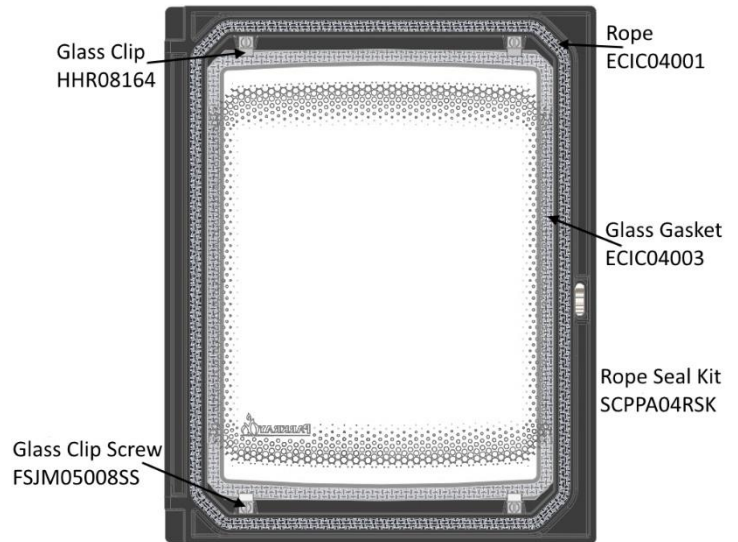

DOOR FRONT VIEW ASPECT 5 COMPACT/ ASPECT 5

**Complete Door
ECIC05arrt002**

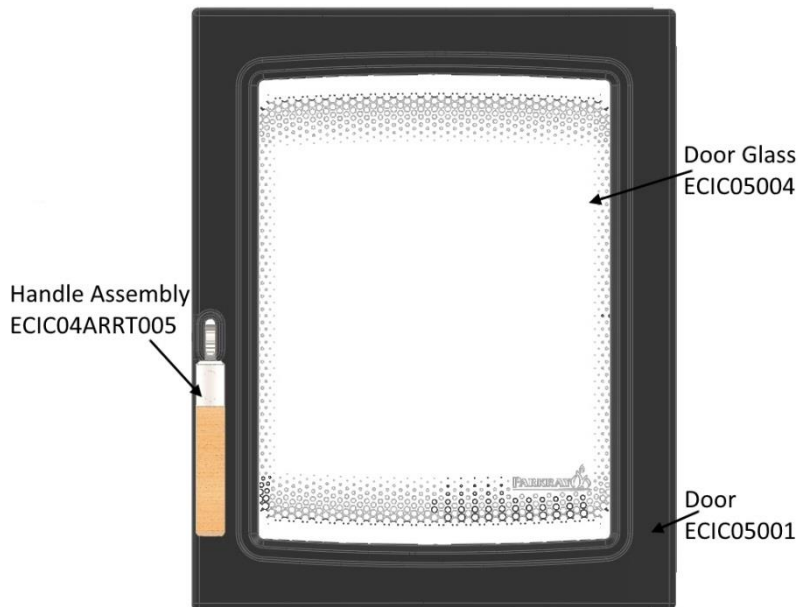

DOOR REAR VIEW ASPECT 5 COMPACT/ ASPECT 5

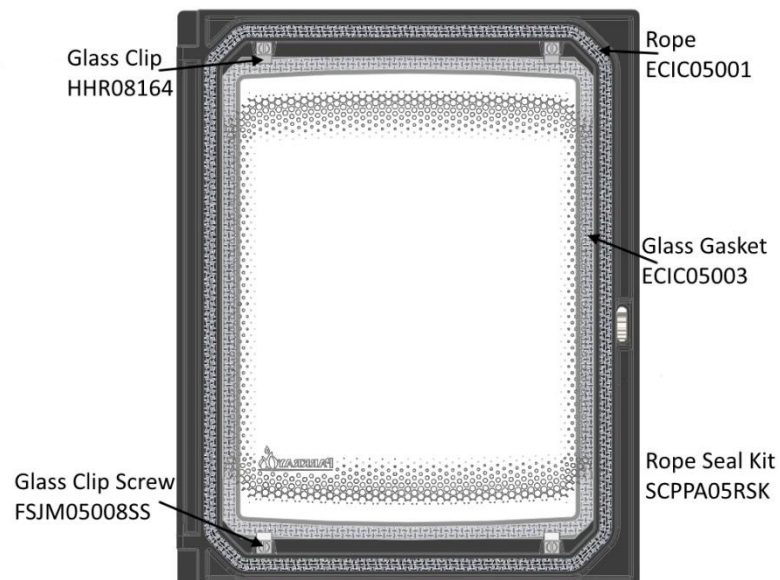

BODY ASSEMBLY SPARES ASPECT COMPACT 4 AND 4

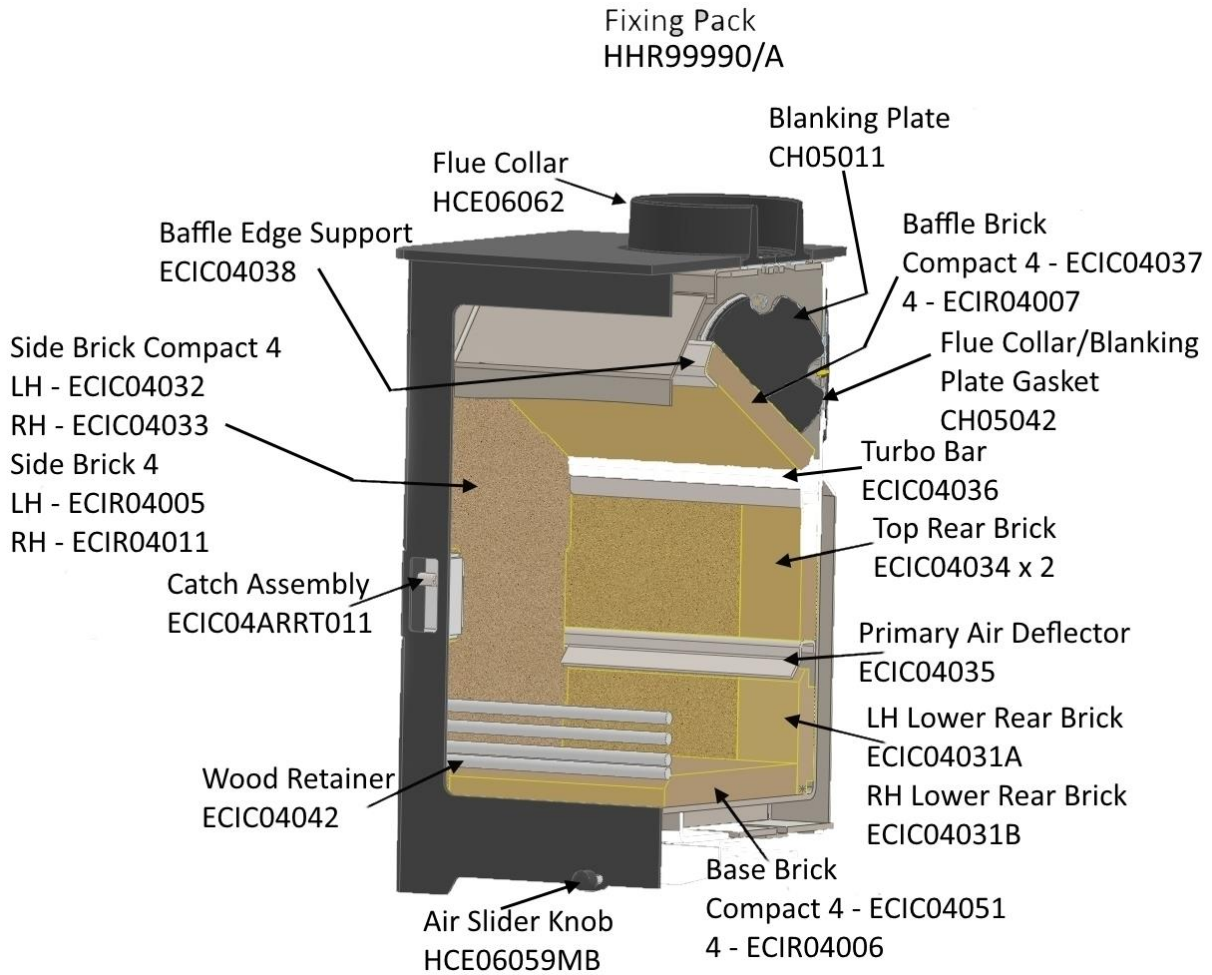

BODY ASSEMBLY SPARES ASPECT COMPACT 5 AND 5

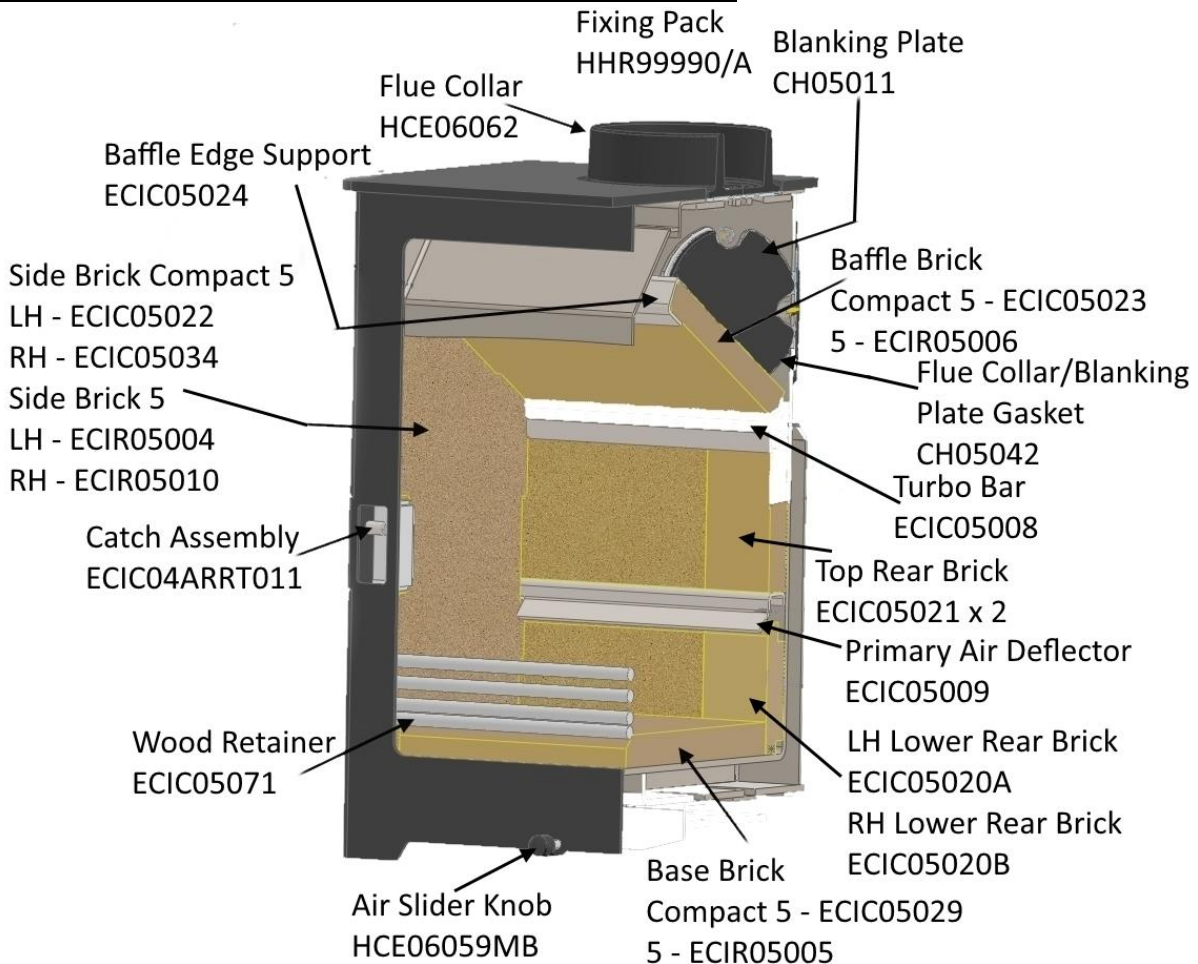

INSTALLATION & COMMISSIONING CHECKLIST

PURCHASE INFORMATION	
Dealer/Retailer Name	
Address	
Telephone Number	
Email	
Date Purchased	

INSTALLER INFORMATION	
Installer Name	
Address	
Telephone Number	
Email	

APPLIANCE INFORMATION	
Date Installed	
Appliance Stock Code	
Appliance Description	
Serial Number	

COMMISSIONING CHECK (Complete & Sign)		
	YES	NO
Does the chimney/flue system meet the appropriate standard?		
Has the chimney/flue system been swept and passed the soundness test?		
Has this appliance passed the flue draught test?		
Please write down the flue draught reading:		
Has this appliance passed the smoke test?		
Has this appliance passed the spillage test?		
Have you explained how to operate the appliance and explained the controls?		

Signature:	Print Name:
------------	-------------

SERVICE RECORDS

1st Service	
Date of Service	
Date of next Service	
Servicing Company/ Engineer	
Signature	

3rd Service	
Date of Service	
Date of next Service	
Servicing Company/ Engineer	
Signature	

5th Service	
Date of Service	
Date of next Service	
Servicing Company/ Engineer	
Signature	

7th Service	
Date of Service	
Date of next Service	
Servicing Company/ Engineer	
Signature	

9th Service	
Date of Service	
Date of next Service	
Servicing Company/ Engineer	
Signature	

2nd Service	
Date of Service	
Date of next Service	
Servicing Company/ Engineer	
Signature	

4th Service	
Date of Service	
Date of next Service	
Servicing Company/ Engineer	
Signature	

6th Service	
Date of Service	
Date of next Service	
Servicing Company/ Engineer	
Signature	

8th Service	
Date of Service	
Date of next Service	
Servicing Company/ Engineer	
Signature	

10th Service	
Date of Service	
Date of next Service	
Servicing Company/ Engineer	
Signature	

2 year standard warranty

Any appliance bought through the showroom of an authorised Hunter Stoves Group dealership will automatically be covered by our standard 2 year conditional guarantee.

However this standard 2 year warranty can be extended to a **5 year** or **10 year** conditional warranty dependent on the model type (5 years- Boiler models, 10 years- Room heater and Gas models).

To qualify for this extended warranty option you need to:

1. Register your purchase online at <https://www.hunterstoves.co.uk/knowledge-hub/warranty-registration/>
2. Retain your proof of purchase.

Warranty conditions

For the Standard 2 year or extended 5/10 year warranty to be valid and to remain in force throughout the warranty period the following must have been carried out:

1. The appliance must have been installed by an appropriately qualified engineer (HETAS or Gas-Safe in the UK) in accordance with the manufacturer's instructions and in compliance of any relevant national or local building regulations.
2. The appliance will need to be registered within two months of purchase and the commissioning and installation documentation completed (these need to be kept by the end user).
3. The appliance must be serviced within 12 months of the installation date for the second year of the standard warranty to be valid, and within every 12 month anniversary thereafter to maintain the validity and coverage of any extended warranty. For this purpose the installation and user instructions, supplied with the appliance, makes a provision for receipts and annual services to be recorded. This is needed in the event of a claim during the warranty period.
4. Only genuine Hunter Stoves spare parts or consumables can be used in the servicing and maintenance of the appliance during any standard or extended warranty period. These can be sourced from your authorised supplier directly or through our website spares portal. www.hunterstoves.co.uk/spares.
5. Any problems or issues giving rise to any claim under the standard or extended warranty must be submitted to the authorised Hunter Stoves Group retailer from whom you originally purchased the appliance. Hunter Stoves Group will then offer appropriate support and help through your original authorised supplier to solve any issues.
6. The standard or extended warranty option is not transferable. It is solely for the benefit of the original purchaser of the appliance. For this purpose please retain the proof of purchase.

Warranty exclusions

No warranty period is extended to naturally-wearing replaceable consumables and spare parts within the appliance. Such parts include, but are not limited to:

For Solid Fuel Stoves:

Glass and rope/ceramic seals
Door handle assembly
Fire bricks
Baffles/Throat plates
Log retainers, grate supports & catch bars
Grate parts
Ash-pans
Clip-in Boilers

For Gas Stoves:

Gas pilot assemblies
Thermocouples and Oxy pilots
Ceramic log & coal 'fuel-effects'

For both Solid Fuel and Gas Stoves:

The paint or surface covering of the appliance:

1. Damage to the paint surface caused by the appliance being stored in a damp and cold environment is not covered on the warranty.
2. In the course of the initial firings of the appliance the paint or enamel surface may change colour. This is considered to be normal and as such is therefore not covered by the warranty.
3. Damaged caused by over firing, resulting in cracking, bubbling or discolouration to the paint or enamelled surface finish is not covered by the warranty.

Warranty limitations

1. Damage to the appliance due to specific local conditions caused by draft or chimney defects.
2. Damage resulting from installation and use where installation is not in accordance with the manufacturer's instructions or local building and/or safety regulations.
3. Damage or premature wear caused by burning inappropriate fuels such as Bituminous coal, "Petro-Coke" or any other Petroleum based coals. Please visit the HETAS website, www.hetas.co.uk, for a full list of approved fuels which are covered by the warranty. Fuels outside of this list are not covered by the warranty.
4. Damage caused by burning material with high creosote content or any other painted/treated timber.
5. Consequential loss to associated non Hunter Stoves Group products is not covered under the warranty.
6. Consequential loss relating to decorations, soft furnishings or other household assets is not covered under the warranty.
7. Cost associated with the removal and re-installation of an appliance subject to a warranty claim.

Hunter Stoves Group total liability will only extend to the total purchase price paid for the goods in any warranty claim. Hunter Stoves Group reserve the right to replace, repair or refund to value of goods purchased.

ANY HUNTERS STOVES GROUP PRODUCT PURCHASED VIA AN INTERNET SUPPLIER, OR THROUGH AN UNAUTHORISED STOCKIST WILL ONLY BE SUPPORTED BY THE STATUTORY, 12 MONTH GUARANTEE AND WILL NOT QUALIFY FOR ANY EXTENDED 5 OR 10 YEAR WARRANTY.

The Hunter Stoves Group extended warranty option does not affect your statutory rights.

This revised standard or extended 5 or 10 year warranty option comes into effect on **1st September 2015** and will apply to all appliances sold from that date.

This standard/extended warranty applies to purchases of Hunter Stoves within the United Kingdom and the Republic of Ireland. Purchases in all other countries are subject to the warranty conditions specified by the distributor in those markets.



hunterstoves
GROUP

Hunter Stoves Ltd, 8 Emperor Way, Exeter Business Park, Exeter, Devon, EX1 3QS
www.hunterstoves.co.uk Email: info@hunterstoves.co.uk